

# Operational & Maintenance Manual

## Semi-Electric Aerial Order Picker

### GOP40S-130/157/177



#### WARNING

THE MANUFACTURERS SHALL NOT BE HELD LIABLE IN CASE OF FAULTS OR ACCIDENTS DUE TO NEGLIGENCE, INCAPACITY, INSTALLATION BY UNQUALIFIED TECHNICIANS AND IMPROPER USE OF THE TRUCK.

DO NOT OPERATE THIS MACHINE UNTIL YOU READ AND UNDERSTAND ALL THE DANGERS, WARNINGS AND CAUTIONS IN THE MANUAL.

## I. PREFACE

Read this instruction carefully before the machine is taken into use to avoid errors. Correct operations and regular inspections are factors of vital importance for the operating economy and lifetime of the machine.

These important parts are described in the following related sections.

All the information contained in this booklet is based on the data available at the time of printing, the manufacturer reserves the right to modify its product at any time, without notice and without liability. It is therefore advisable to regularly check for any changes.

## II. APPLICATION

The semi-electric Aerial Order Picker is the best equipment for materials picking and handling. It's intended for use on plane and level floors. Easy moving and operating. Lift or fall steadily. Safe and reliable. Suitable for order picking application in distribution warehouse.

## III. TECHNICAL SPECIFICATIONS

Technical specifications and major dimensions are shown in TABLE 1 and FIGURE 1, respectively.

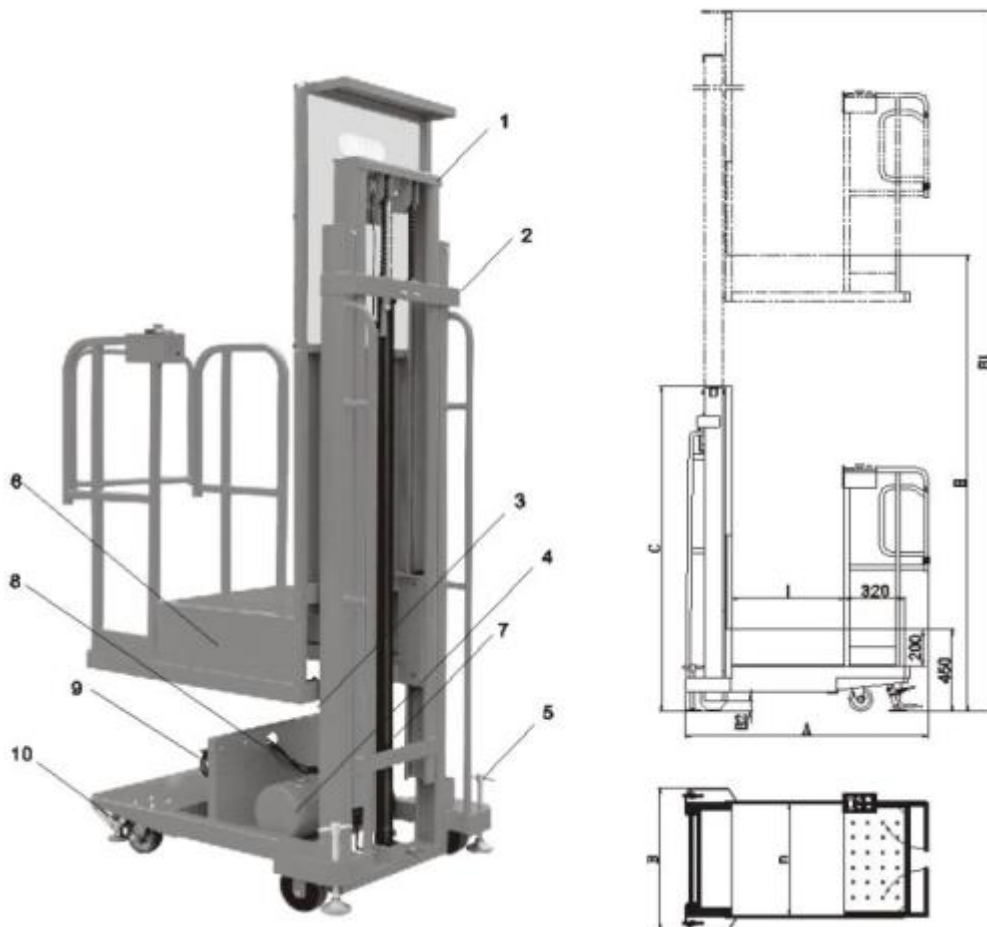

1. Inner mast	2. Outer mast	3. Stop block	4. Hydraulic pump unit	5. Brake shoe
6. Platform	7. Jack	8. Charger	9. Battery	10. Brake

TABLE 1

Model Number	EOPS20 Series		
Lift Height (in)	130	157	177
Lifting Motor (v/kw)	12/1.6		
Load Capacity (lbs)	440		
Platform Size (in)	23.6x25.2		
Net Weight (lbs)	705.5	838	926
Battery Voltage (V/Ah)	12/115		
Ground Clearance (in)	1.2		
Overall Length (in)	51.2		

#### IV. OPERATING GUIDE

##### PRE-SERVICE CHECK

1. If the picker has been damaged during transport, it must not be put into service, and you should immediately contact your dealer.
2. The picker has been lubricated before delivery, and the hydraulic unit has been filled with hydraulic oil.
3. If a battery has been supplied with the picker, the battery is charged. Check that the acid level is correct in each cell and that the specific gravity is in order. (See "Maintenance Guide ")

##### OPERATION OF PICKER

1. Turn the key and switch on, the display indicator shows.
2. The platform rises when you turn the SWITCH button to its on-position and the UP button is pressed at the same time. Upon loosening the buttons, the platform stops.
3. The platform falls when you turn the SWITCH button to its on position and the DOWN button is pressed at the same time. Upon loosening the buttons, the platform stops.
4. A big mushroom-shaped button is provided for emergency stop. This should be used only when other means to stop the platform moving fails. Reset the button by turning the knob in the direction shown by the arrow. Do not pull the knob.

#### V. MATTERS NEEDING ATTENTION

1. Please use brakes and brake shoes when it is working.
2. The goods should be put on the platform evenly. It is forbidden to be too heavy.
3. The platform should fall down to the bottom when you are moving the picker to another working area.
4. Forbid standing under the platform when it is working.
5. Forbid laying the picker on a slope.
6. Please use a stop block during overhaul of the hydraulic pump unit or battery.

#### VI. MAINTENANCE GUIDE

##### CONTROL CHECK

Preventive overhaul based on regular checks of the machine will minimize faults, and possible defects may be corrected before serious breakdowns take place.

The battery is the source of power for the machine. It is necessary to follow the instructions given to obtain full output, satisfactory battery lifetime, and to keep the machine in the best condition.

#### DAILY CHECK

1. Check that the battery is fully charged (see also the section of the battery).
2. Lift the platform to its top position to check that there is enough hydraulic oil in the system. Refill, if necessary, with YA-N32 or a similar oil.

#### WEEKLY CHECK

The user of the picker should spend a few minutes every week on checking.

Special attention should be paid to the wheels and axles—see if there is thread, rags, or similar debris blocking them.

#### HALF-YEAR CHECK

1. Lubricate the lifting chain. Check the chain for wear.
2. Check and tighten any loose screws, nuts, and the cable joints of the battery.
3. Check the brush inside the pump motor and correct any irregularities to maintain good contact.

#### OIL CHANGE IN THE HYDRAULIC SYSTEM

We recommend changing the hydraulic oil after one month's operation (or 200 hours), and even if the operation time has not reached, change the oil once a year. Use hydraulic oil YA-N32 or similar. The oil should be filtered clean and maintained at an adequate level.

When you have lifted and lowered the platform 2 or 3 times, there will be no more air in the system, and the machine will work normally again. If the lift height has not been achieved, it is necessary to refill.

Do not dump the dirty hydraulic oil randomly after changing it. The used oil must be disposed of according to special prescriptions and in compliance with the current legal provisions in the area and country where the machine is used.

#### BATTERY

**Maintenance:** To ensure the battery's better performance and prolong its usage life, examine the liquid level regularly. If the liquid level is below the lower line, please add distilled water or purified water till the level reaches the upper line. Refilling must not take place until the charging has been finished, as the acid expands during charging. The battery surface must be kept clean and dry, and this will cause leakage of current and consequently reduce battery capacity. **Battery charging:** turn the key and switch on, when the display indicated voltage is below 11 volts, please charge the battery in time. If the battery is not charged in time, it will damage the battery. During installation, 1/10 electric current of the battery's capacity should be charged for 3~5 hrs. After charging, the terminal voltage of the battery should be above the lower line. Otherwise, charge the battery again.

Battery charging should be done in a well-ventilated place and there is no naked flames, no sparks and no heat radiation sources nearby.

After finishing charging, turn the screw bolt of liquid box tightly, wash the surface of battery with clean water and clean it gently with wet cloth. When charging up the battery, if the battery temperature of the battery is above 45°C, stop charging immediately, continue charging only after the liquid temperature drops.

## VII. HANDLING AND STORAGE

The SEMI-Electric Aerial Order Picker must be stored in a horizontal position, in order to prevent the oil and the electrolyte will overflow when transporting and storing.

When stores it, it must be kept clean and kept far away from the damp and bad climate. The temperature of environment should be no more than 40°C. If the battery isn't working for a long time, it should be recharged timely.

## VIII. COMMON FAULTS AND SOLUTIONS

Faults	Source of faults	Solutions
Turn the key and switch on, The electricity indicator is not on	Loose terminals, disconnection of electric contact, bad contact of switch	Examine the terminals of battery, screw tight the screw of bolt and nut, switch contact should be good
Extending speed of piston rod in lifting oil tank is not uniform	Air existence in the oil tank within	Start the machine for two or three times, discharge air in the oil tank
Shortage of hydraulic oil	---	Add hydraulic oil
Voltage of storage battery is below the allowable value	---	Charge up the battery
Lifting oil tank can't lift	Oil leakage	Examine and repair, replace the piece of seal and sleeve of oil pump
---	Overload	The lifting load should not exceed the rating value
Transmission chain is pressed singly	Abrasion of transmission chain and chain wheel caused by long-term use	Replace the transmission chain and chain wheel
---	Shortage of hydraulic oil or oil polluted	Add hydraulic oil or replace hydraulic oil with clean oil
Strange noise of power system during the process of lifting	Displacement caused by blocking up of electric machinery and its shell	Screw and fix screws
---	Excessive humidity of the surroundings	Surrounding humidity $\leq 90\%$

IX. SPARE PARTS

ITEM	DESCRIPTION	QTY	ITEM	DESCRIPTION	QTY
1	Outer mast frame	1	41	Chain	2
2	Brake	2	42	Chain tightener	2
3	Washer	38	43	Roller	8
4	Caster	2	44	Bearing	8
5	Bolt	18	45	Circlip	8
6	Nut M10	22	46	Piston rod	1
7	Tightening pin	2	47	Spacer sleeve	1
8	Rear wheel assembly	2	48	O-ring	1
9	Axle	2	49	Piston	1
10	Bolt	6	50	Gasket ring	1
11	Grower washer	10	51	Nut	1
12	Brake shoe	2	52	Retainer pin	1
13	Bolt	2	53	Explosion relief valve	1
14	Circlip	5	57	Cylinder	1
15	Stop block	1	58	Anchor loop	1
16	Roller	2	59	Rubber pad	1
17	Bush	2	60	Nut	4
18	Circlip	4	61	O-ring	1
19	Pin	2	62	O-ring	1
20	Bolt	2	63	Cylinder cap	1
21	Tightening cap	2	64	Dust seal	1
22	Transition joint	2	65	Plastic clamp	2
23	Joint	1	66	Protective screen	1
24	Condulet pipe	1	67	Adjusting screw	2
25	Pin	1	68	Nut	4
26	Circlip	2	69	Lateral roller	4
27	Oil hose assembly	1	70	Bush	4
28	Hydraulic power pack	1	71	Lateral roller retainer	2
29	Cable assembly	1	72	Lateral roller retainer	2
30	Battery	1	73	Circlip	8
31	Circlip	9	74	Work platform	1
32	Nylon pulley	1	75	Tightening pin	2
33	Sprocket shaft	1	76	Rod	2
34	Spacer	1	77	Spring	2
35	Inner mast assembly	1	78	Gate	2
36	Bolt	1	79	Panel box	1
37	Sprocket shaft	1			
38	Circlip	1			
39	Bearing	2			
40	Sprocket	2			

# SEMI-ELECTRIC AERIAL ORDER PICKER

